

INTRODUCTION

Your rectifier is fully controlled by a microprocessor and is suitable for automatic recharging of lead batteries. The recharging cycle is of the Wa type (decreasing current) or of the rapid WoWa (double curve) depending on the model purchased (see rating plate). For best results and safety, the user is required to read, follow and keep these instructions carefully. This device is to be used exclusively for recharging lead batteries of the voltage and capacity indicated in the paragraph entitled BATTERY. The manufacturer is not responsible for any damage due to improper use. This device is designed for use only in environments that are protected from any atmospheric disturbance.

BATTERY

This rectifier should be used to charge batteries that have the following characteristics:

- battery type: lead, unsealed
- rated voltage: see rating data on rectifier (e.g. 12 Volt)
- capacity: the optimum value can be calculated on the basis of rated rectifier current I_n (see rating plate):

Wa cycle: **$C = I_n \times 6$**
(e.g.: $I_n = 30A$ capacity will be $C = 180 Ah \pm 10\%$)

WoWa cycle: **$C = I_n \times 4$**
(e.g.: $I_n = 30A$ capacity will be $C = 120 Ah \pm 10\%$)

INSTALLATION

To ensure maximum safety, the installation has to be carried out as indicated by the manufacturer. Installation and any work on the rectifier must be carried out by qualified technical personnel. Install only after disconnecting the supply cable from the mains power supply and the output cables from the battery. After unpacking, ascertain that the device is in perfect condition. In case of doubt, do not use the device and contact the supplier. Install the rectifier in a protected place; do not install it:

- outdoors or in open sheds;
- in any damp or dusty place or in presence of acids;
- in any place with temperatures below 0 and above 40°C (32 and 104° F);
- in any place that is in any way unsuitable for electronic devices.

Do not obstruct the ventilation apertures and do not cover during operation.

POWER SUPPLY

Ascertain that the rating plate values are compatible with your mains power supply (mono-phase/three-phase, voltage, frequency, power).

If the rectifier is designed to operate at double voltage (230V and 400V) check that it is connected for the exact value of your mains power supply and if necessary modify. Plug it into a tap that is equipped with protection that complies with standard regulations. If you have to use an extension cable, contact the manufacturer for correct technical information. The supply cable must be replaced only by qualified personnel.

INITIAL CALIBRATION

To adapt the rectifier to the normal variations of voltage in the mains power supply ($\pm 10\%$ with respect to the rated value) open the rectifier (see Fig. 2) and move the BLUE wire (3 wires in case of three-phase rectifier) to the correct position shown on the table. This operation is fundamental for correct operation and should be performed only when installing the rectifier.

CONNECTION TO BATTERY

When connecting to the battery respect polarity (red wire to +, black wire to -). Wrong connection will immediately blow fuse F2 (Fig. 2) that has to be replaced with one of the same value. If you need to use an extension lead, contact the manufacturer first.

SWITCHING ON

The device can only be switched on when the battery is connected correctly. When switched on, the microprocessor carries out the VISUAL TEST and DELAY PROGRAMMING steps and if the operator does not program any delay as described below, it starts PHASE 1.

VISUAL TEST

All sections of the screen are lit up for 2 seconds for visual checking of the circuit operation, then the microprocessor moves on to the DELAY PROGRAMMING step.

DELAY PROGRAMMING

For 6 seconds the screen displays “- ---”. Press SEL to program, otherwise after 6 seconds the microprocessor moves to PHASE 1. When you press SEL, “H 00.5” appears on the display, indicating that you have programmed half hour's delay. Next press SEL to set the desired time (maximum 25.5 hours). After 6 seconds from the last keystroke the programmed time is memorised and the display begin to flash to indicate that it is starting the countdown of the hours set. When it reaches zero it will start PHASE 1. Once the delay has been memorised it cannot be changed again except by disconnecting the battery and starting all over again. This delay

can be programmed to be the same at each switching on or not, as preferred. Ask the installer to set the function to suit you. Delay programming makes it possible to use off-peak rate electricity and to let the battery cool before recharging.

PHASE 1

This is the first charging phase. The rectifier supplies current to the battery and the voltage in the battery increases. The initial current (with the battery completely discharged, 2V/element) is the same as the nominal value of the rectifier and will tend to decrease over time. With partially discharged batteries the current is lower. When the voltage in the battery reaches 2.40V/element (gasification) the microprocessor activates PHASE 2 (usually within 6-8 hours for the Wa cycle and 4-5 hours for the WoWa cycle). The display 1 shows "C" while the display 2 normally shows the value of current being supplied, except when you press SEL (see SEL KEY) or when it indicates error status (see ERROR STATUS).

STOP PHASE 1

If the battery voltage does not reach 2.40 V/element within 9 hours the microprocessor interrupts charging and the display show "1 Err" (see ERROR STATUS). This may happen because of a problem with the battery (too old or with a broken element) or because of a problem with the power supply. This situation indicates an existing anomaly. If it happens often, inform the supplier. Press SEL (see SEL KEY) to read the final capacity and voltage values reached by the battery.

PHASE 2

This phase is also called the final phase, and enables the battery to be 100% recharged. The microprocessor calculates the time necessary (minimum 30 min, maximum 5 hours), which depends on the behaviour of the battery. For WoWa cycle models the passage from PHASE 1 to PHASE 2 is signalled by a clearly audible noise generated by the internal switching with the consequent drop in the supplied current.

Unlike PHASE 1, the screen displays "F".

STOP PHASE 2

After the calculated time, the microprocessor stops charging and the display 1 show "S". The battery is ready for use. Press SEL (see SEL KEY) to read the final voltage and capacity values reached by the battery.

FORMING PROCESS-EQUALIZATION

Once PHASE 2 has ended, the microprocessor is able to activate the FORMING process and/or the EQUALIZATION charge depending on how it has been programmed - ask the installer. During these charges, "E" will be displayed on screen 1 and the current supplied to the rectifier on screen 2 (only "E" during the wait phases).

SEL KEY

The SEL key can be used to display 2, at any time, the battery voltage value (in V/element) and the capacity released by the rectifier (in Ah=ampere hours). Pressing the key once displays the voltage in V/element (e.g. "U 2.00") for 6 seconds. Pressing the key twice displays the capacity in Ah (e.g. "0012") for 6 seconds. After that time the display returns to shows the current. The display shows the values corresponding to the current status of the battery, except when stops are activated: in these cases the display shows the last values read and memorised before activating the stop.

Note: the three values on the display are distinguishable as following:

Display 1	Display 2	Description
"C"	"020"	20A in FASE 1
"U"	"2.00"	2.00V/element
"0"	"140"	0140Ah

STOP KEY

If it is necessary to stop charging, press the STOP key for at least 2 seconds. Pressing it for a shorter time will have no effect.

Display will shows STOP. When the stop key is pressed, it is not possible to start the rectifier again until the battery has been disconnected for at least a few seconds. To obtain the best possible recharge, never interrupt the automatic cycle, but wait until the microprocessor signals a stop status.

PUMP

For WoWa models, this rectifier envisages the use of the pump. When the pump is activated, a dot on display 1 of the microprocessor signalling the pump's activation will light up.

BUFFER

If you leave the rectifier connected even during long inactive periods, you can maintain the battery charged at 100%. At the end of the recharging cycle the BUFFER charge goes into operation. This consists of alternating an active and a passive phase without any time limit. Active phase: the rectifier supplies current for 5 minutes.

Passive phase: the rectifier does not supply any current for 8 hours. In this situation you can leave the rectifier connected for months and it will compensate for the self-discharge process of a battery. The screen displays "P" during this charge while screen 2 displays the value of the current supplied by the rectifier (only "P" in the passive phases)

SIMPLIFIED DISPLAY

It is possible to program activation of the simplified display (ask the technical assistance service). ON will be displayed on screen 2 during charging and STOP when charging has been completed. The supply of current is shown by the movement of a segment on screen 1. The SEL key (see SEL KEY) is deactivated and the STOP key (see STOP KEY) will be active. Any errors (see ERROR STATUS) will be displayed.

ERROR STATUS

When the microprocessor finds a problem, it stops the rectifier and displays an error message that enables the user to identify the fault: *CAUTION: first, disconnect the power supply and then the battery before adjusting the equipment.*

"**1 Err**" indicates that the microprocessor has interrupted the charge because the battery has not reached the THRESHOLD VOLTAGE within 9 hours (see STOP-PHASE 1).

"**2 Err**" the microprocessor has detected a possible internal malfunction. Unplug the rectifier, then disconnect the battery and call a technician.

"**3 Err**" means the voltage of the battery that you have just connected is too low (less than 1.5 V/ℓ). Check the battery. The status is removed when the voltage in the battery rises beyond that limit.

"**4 Err**" means the voltage of the battery that you have just connected is too high (more than 2.4 V/ℓ). Check the battery. The status is removed when the voltage in the battery descends below that limit.

"**5 Err**" means output fuse F2 (see Fig. 1) has blown. Replace the fuse.

"**6 Err**" The microprocessor has detected a malfunction in the PUMP (OPTIONAL).

"**7 Err**" indicates absence of mains power supply. This may be due to an interruption on the mains line or the plug may not be inserted or fuse F1 may have blown (Fig. 2). The situation returns normal as soon as power is restored.

"**8 Err**" the microprocessor has detected anomalous battery voltage behaviour (insufficient initial voltage increase), have the battery checked by a technician.

SPECIAL SIGNALS

Should the red led on display 1 light up independently from the signal of the display itself, disconnect the rectifier and contact the technical assistance office.

GENERAL RECOMMENDATIONS

Do not let the battery run down completely. If recharged when only partially discharged, the battery will last longer and the rectifier will do a better job. Prevent oxidation of the battery contacts. Never disconnect the battery if the rectifier is supplying current as the break-off spark could ignite the gases produced by the battery. Keep the charging area ventilated.

MAINTENANCE

The rectifier does not require any maintenance. For cleaning the outside, use a damp cloth. Use manufacturer approved spare parts.

INSTRUCTIONS FOR RECTIFIERS serie MICRO-DIGITAL A (mono-phase - three-phase)

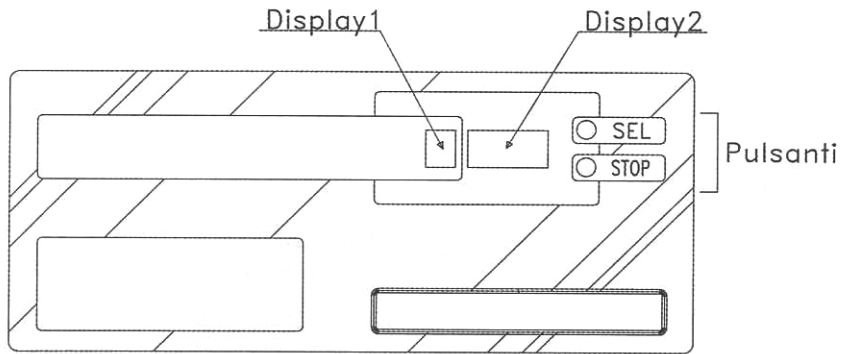

FIG. 1

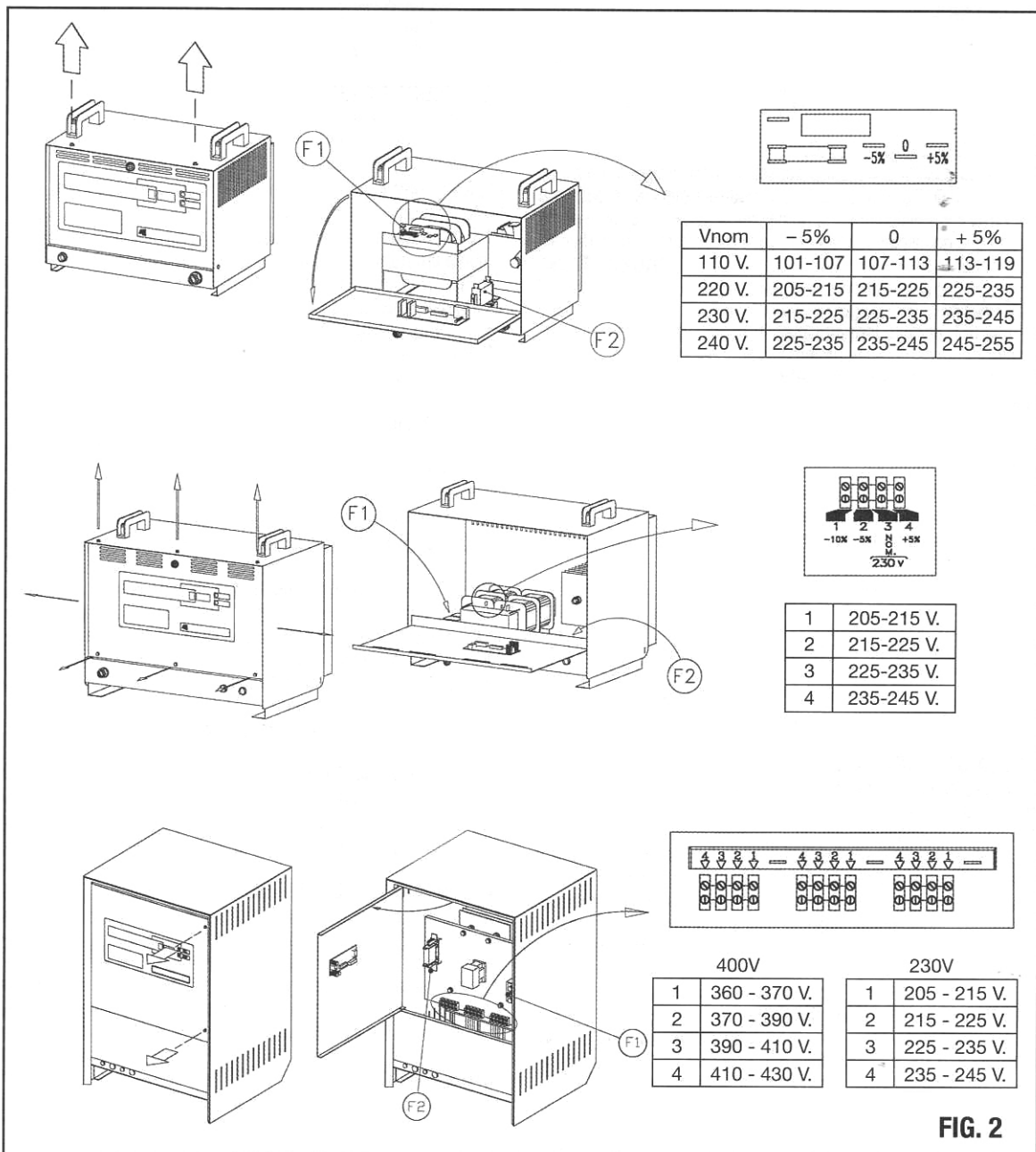

FIG. 2